



RIMORCHI PROFESSIONALI E SPORTIVI

FAUTRAS

UN AZIENDA FAMILIARE FRANCESE ...



Jean De Vincenzi nel 1972 sulla sua moto da trial



Marie-Noëlle Fautras in competizione

«La passione per il motociclismo tramandata da mio papà!»

«Maestro di scuola a St Georges du Rosay (72), mio padre era appassionato di motociclismo. Da bambina, tra il 1965 e il 1972, lo seguivo sulle piste e camminavo per km per vederlo gareggiare.

Nel 1972 lasciò il lavoro per diventare importatore di trailer britannici. Ho ammirato il suo modo di fare affari e ho deciso di subentrare nel 1982 nel sud-ovest della Francia con mio marito. Nel 1992 abbiamo prodotto il nostro primo rimorchio, è nato il marchio Fautras.»

Marie-Noëlle Fautras



Marie-Noëlle e Jean-Luc Fautras (I creatori del marchio Fautras)



Elise, Jean De Vincenzi, Marie-Noëlle, Jean-Léonard e Jean-Luc Fautras

«Dalla passione ai trasporti»

Nel 1988, Marie-Noëlle Fautras acquista la sua prima motocicletta per gareggiare. Prima ha trasportato la sua moto su un rimorchio a pianale, poi ha deciso di utilizzare i trailer per cavalli.

Consapevole del problema del peso e dell'ingombro, chiese al marito di realizzare un "Mini van".

No molto rapidamente da subito i piloti che incontrava nelle gare dei rally (Cyril Després, Luc Alphanth, Laurent Bourgnon, Thierry Bethys , Richard Saint , Arnaud Demester , ecc.) aderirono al concetto: è nato il rimorchio per il tempo libero!



Jean-Luc Fautras consegna il testimone a suo figlio, Jean-Léonard Fautras



Un giovane direttore, Jean-Léonard Fautras

«Una passione tramandata»

Nel 2011 la gestione della ditta Fautras è stata tramandata al figlio Jean-Léonardo Fautras.

«Sono fortunata di avere la mia una famiglia che si fida di me. Mio padre nel design, mia madre nello sviluppo aziendale: formiamo una buona squadra e facciamo delle nostre complementarietà una risorsa.»

Jean-Léonard Fautras

1972



Jean De Vincenzi importa in Francia i trailer per cavalli britannici

1982



Jean-Luc e Marie-Noëlle Fautras riprendono l'importazione di trailer britannici

1992



Nascita di Vans Fautras con il lancio dei primi trailer e rimorchi europei con apertura all'americana (2 porte posteriori)

1997



Marie-Noëlle Fautras crea la gamma professionale e sportiva (rimorchi, Carella, furgoni per moto, quad, autoscuole, ecc.) con il modello PODIUM

2002



Commercializzazione del modello MAXIPODIUM

2007



Commercializzazione del modello OLYMPIUM

2010



Lancio del marchio Fautras negli Stati Uniti

2022



Commercializzazione del modello OLYMPIUM Ruote interne

Produzione francese al **100%**

Con una sede e un sito produttivo situati in Dordogna, il marchio è, dalla progettazione alla produzione, al 100% francese.

Scopri il punto vendita più vicino a te sul sito www.fautras.com.



RIVENDITORI

Scansionami



www.fautras.com/fr/map/loisir

Visita il nostro sito per scoprire l'elenco dei nostri rivenditori e trovare quello più vicino a te.



I VANTAGGI FAUTRAS



Carrozzeria monoscocca aerodinamica in vetro resina

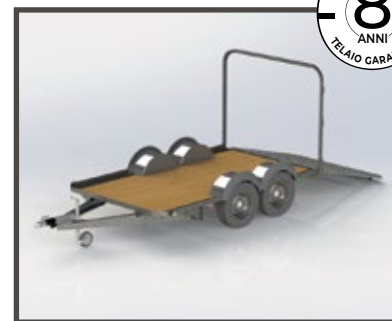

Telaio e struttura zincati a caldo.



Freni ad inerzia e sospensioni a ruote indipendenti (esenti da manutenzione) per un'eccellente tenuta di strada.





OLYMPIUM
CRUISER



OLYMPIUM
CARRERA



OLYMPIUM
TACK

LE NOSTRE SERIE **ICONICHE**

OLYMPIUM CRUISER



Trailer dell'Olympium CRUISER, parti all'avventura!
Scopri un altro modo di campeggiare, bivaccare, avventurarsi.

Aggiungi l'opzione «tenda sul tetto» e fuggi in un altro modo.



Pacchetto "CRUISER" comprende:

- Galleria e scala.
- Kit autonomia elettrica:
Blocco elettrico 220 V (2 prese "rete" interne e 1 presa esterna roulotte) + Blocco solare 12 V (pannello solare, 1 batteria, 1 presa USB e 1 presa accendisigari).
- Decorazione «CRUISER».



OLYMPIUM CARRERA

Appositamente progettato per gli amanti degli sport motoristici, il rimorchio Olympium CARRERA è perfetto per trasportare le vostre moto, quad, MP3, sidecar, scooter.

Che sia per il tempo libero o per la competizione, questo carrello è il tuo alleato.

Con il pack "CARRERA", il tuo rimorchio è dotato di:

- Pedana posteriore e porta laterale.
- Sistema di bloccaggio della moto (da 1 a 3).
- Guide e attacchi a pavimento (una confezione).
- Blocco elettrico 220 V (2 prese "rete" interne e 1 presa roulotte esterna).
- Cerchi in alluminio.
- Fanali a LED.
- Decorazione «CARRERA».



OLYMPIUM

TACK

Il rimorchio OLYMPIUM TACK è progettato per gli sport equestri. Grazie alla sua altezza interna e al suo verricello, è perfetto per trasportare un baule e tutta l'attrezzatura utile per le vostre gare.

Con il pack "TACK" il tuo rimorchio è dotato di:

- Pedana posteriore con ribalta per facilitare il carico del baule.
- Porta anteriore per accesso laterale.
- Verricello elettrico con telecomando.
- Ganci sul pavimento, ideali per fissare il carico.
- Blocco elettrico 220 V (2 prese "rete" interne e 1 presa camper esterna).
- Decorazione OLYMPIUM "TACK" (colori a scelta).





CONFIGURA IL TUO RIMORCHIO

1 LUNGHEZZA INTERNA



OLYMPIUM*

MAXIPODIUM

QUELLO CHE VOGLIO PORTARE

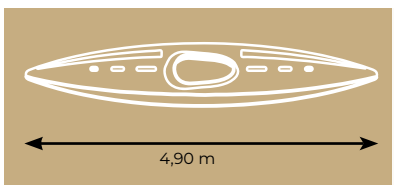
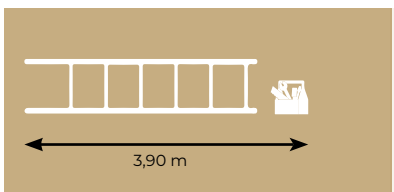
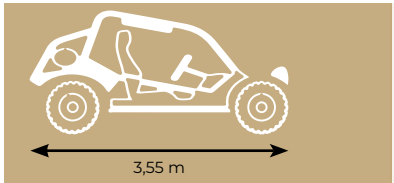
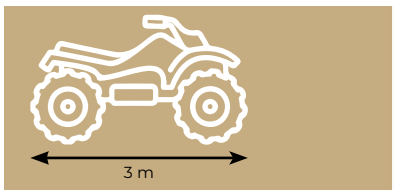
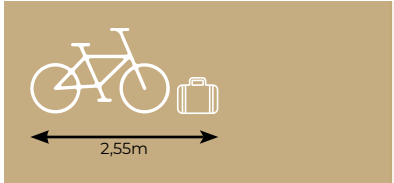

IL MODELLO ADATTO

OLYMPIUM
260



OLYMPIUM
300



OLYMPIUM
360



MAXIPODIUM
400



MAXIPODIUM
500



*Possibilità senza patente BE secondo la normativa vigente e veicolo trainante

2 PESO E NUMERO DI ASSALI

	QUELLO CHE VOGLIO PORTARE	OLYMPIUM 260	OLYMPIUM 300	OLYMPIUM RI 300	OLYMPIUM 360	MAXIPODIUM 400	MAXIPODIUM 500	PESO TOTALE AUTORIZZATO (F2) DA DEFINIRE AL MOMENTO DELL'ORDINE
1 assale	 FINO A 800 Kg	 380 Kg*	 450 Kg*	/	 500 Kg*	/	/	Da 750 a 1300 kg
2 assali	 FINO A 1 400 Kg	/	 530 Kg*	 660 Kg*	 570 Kg*	/	/	Da 1300 a 2000 kg
2 assali	 FINO A 1 900 Kg	/	 530 Kg*	 660 Kg*	 570 Kg*	 880 Kg*	 1080 Kg*	Da 2000 a 3000 kg
		/	/	/	/	 880 Kg*	 1080 Kg*	Da 3000 a 3500 kg

* Peso a vuoto esclusa opzione





















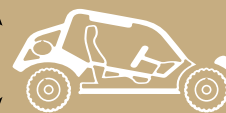

Come calcolo il peso di ciò che posso trasportare?

[MASSA COMPLESSIVA DEL RIMORCHIO] - [PESO A VUOTO DEL RIMORCHIO] = [CARICO UTILE DEL RIMORCHIO]



























3 ALTEZZA INTERNA

QUELLO CHE VOGLIO PORTARE		OLYMPIUM 260	OLYMPIUM 300	OLYMPIUM RI 300	OLYMPIUM 360	MAXIPODIUM 400	MAXIPODIUM 500
H1	1,50m 						
H2	1,69m 						
H3	1,97m 						

 STANDARD  OPZIONALE  IMPOSSIBILE * DISPONIBILE SOLO CON ASSALI POSTERIORI

4 TIPOLOGIA DI APERTURA

COME VORREI CARICARLO		OLYMPIUM 260	OLYMPIUM 300	OLYMPIUM RI 300	OLYMPIUM 360	MAXIPODIUM 400	MAXIPODIUM 500
2 PORTE	 						
PEDANA	 						
TENDA DA SOLE	 						

 STANDARD  OPZIONALE  IMPOSSIBILE

5 FINITURA

1. SCELGO IL COLORE DELLA CARROZZERIA

STANDARD



BIANCO



GRIGIO PERLA



GRIGIO TOPO



AVORIO

OPZIONALE



ROSSO LAMPONE



ARANCIA PURA



LIMONE GIALLO



TURCHESE



BLU PASTELLO



BEIGE GRIGIO



GRIGIO ANTRACITE

2. PERSONALIZZO CON STRISCE DECORATIVE



o



SCEGLI TRA OLTRE 30 COLORI!



ALTRE DECORAZIONI SU RICHIESTA



6 OPZIONI

SCELGO I MIEI OPTIONAL E I MIEI ACCESSORI:



Porta laterale



Tendalino con apertura laterale



Oblò sul tetto traslucido



Griglia di ventilazione bassa



Pedana in alluminio



Ribalta per prolungare la pedana



Blocco ruota rimovibile



Blocco ruota basculante



Blocco ruota regolabile con cavalletto anteriore



Sistema di bloccaggio tanica (2x20l o 4x10l)



Guide di fissaggio laterali
(La confezione = 4 guide + 6 clip)

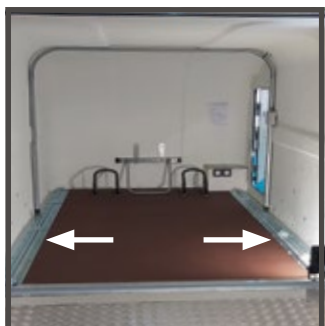

Guide e attacchi a pavimento
(La confezione = 2 binari da 1,5 m + 6 clip)



Terza luce di stop posteriore



Pacchetto luci a LED



Allarme



Verricello con batteria



Pacchetto cambio ruota (asse singolo)



Pacchetto cambio ruote (doppio asse)



Cerchi in lega



Tenda da tetto con scaletta



Kit autonomia solare (blocco 220 V + blocco solare 12 V)



Blocco elettrico 220v (2 prese di rete + 1 presa camper)



I NOSTRI MODELLI **PRO E SPORT**

OLYMPIUM

DESIGN E MODULARITÀ

Evolutivo e modulare grazie ai numerosi optional proposti, l'OLYMPIUM ideale ed essenziale per il trasporto di biciclette, scooter, moto, sidecar, quad, buggy, kart, utilitarie, ecc.

Chi lo utilizza l'apprezza per la ridotta altezza da terra e il comodo volume utile. Questo rimorchio, piacevole da trainare e facilmente convertibile, costituisce un carrello ideale e essenziale per i camperisti.

Questo rimorchio furgone, monoscocca interamente in vetro resina, trainabile senza patente BE* dal design moderno è la soluzione al sovraccarico. È disponibile in 3 modelli: 260, 300 e 360.

Dotazione di serie: freno ad inerzia, ruotino jockey automatico, cavalletto stabilizzatore, luce interna, antifurto integrato nel gancio, 2 porte posteriori.



OLYMPIUM
260



OLYMPIUM
300



OLYMPIUM
360

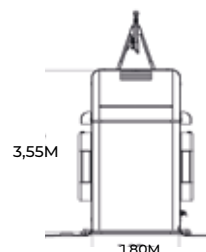
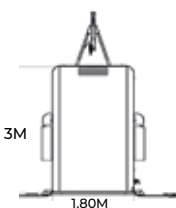

Scopri tutte le caratteristiche dell'OLYMPIUM - Pagina 23



FAUTRAS

FAUTRAS

EQUIFIRST
Herbs & Eye Mix

OLYMPIUM RI *RUOTE INTERNE*

DESIGN E MODULARITÀ

Appositamente progettato per insegnamento della patente B96 e BE. Il suo design compatto e aerodinamico facilita le manovre in città.

L' Olympium 300 RI è molto facile da manovrare e occupa poco spazio. Con le sue ruote interne, farà risparmiare spazio nei tuoi spazi privati.

Aggiungi l' opzione "guide di fissaggio laterali " e organizza il tuo rimorchio in base alle tue attività e ai tuoi hobby (artigianato, windsurf, modellismo , aeromodellismo , ecc.)

Dotazione di serie: freno ad inerzia, ruotino automatico, apertura posteriore con 2 ante, luce interna, cavalletto stabilizzatore, 4 guide incastrate con 6 attacchi a pavimento.



OLYMPIUM RI
300

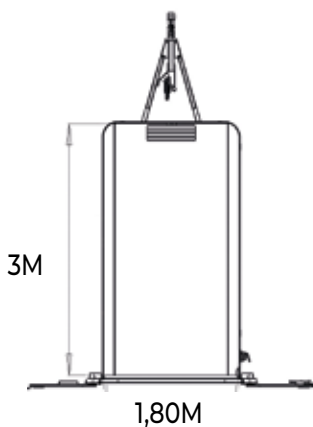

Scopri tutte le caratteristiche dell'OLYMPIUM RI - Pagina 23



HOTEL

FAUTRAS

FAUTRAS

AUTO ECOLE

MAXIPODIUM

AERODINAMICA E VOLUME MAXI!

Questo rimorchio monoscocca interamente in vetro resina è molto aerodinamico e offre un grande volume.

Il Maxipodium viene utilizzato principalmente per il trasporto di moto, auto, quad, moto d'acqua, ecc. e può anche essere convertito in rimorchio negozio, food truck, officina.

Questa gamma offre diverse opzioni di apertura e diversi accessori per adattarsi al tuo progetto.

Il Maxipodium è disponibile in 2 modelli Maxipodium 400 e Maxipodium 500.

Dotazione di serie : freno ad inerzia, 2 assali, cavalletto stabilizzatore, due luci interne, antifurto integrato nel gancio di traino e 2 porte posteriori.



MAXIPODIUM 400



MAXIPODIUM 500

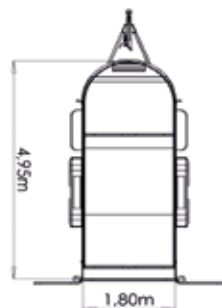
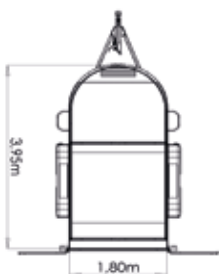

Scopri tutte le caratteristiche dell'MAXIPODIUM - Pagina 23



PADDOCK

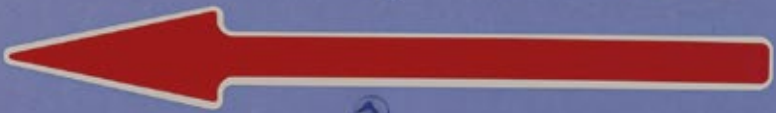

DOTAZIONI E DIMENSIONI

	OLYMPIUM 260	OLYMPIUM 300	OLYMPIUM RI	OLYMPIUM 360	MAXIPODIUM 400	MAXIPODIUM 500
CARROZZERIA MONOSCOCCA IN VETRO RESINA , PAVIMENTO IN LEGNO MARINO A ALTA RESISTENZA ANTISCIVOLO						
FRENATURA AD INERZIA E SOSPENSIONI A RUOTE INDIPENDENTI						
STRUTTURA E PARTI IN ACCIAIO ZINCATO A CALDO						
SERRATURA A CHIAVE + SERRATURA ANTIFURTO INTEGRATO NEL GANCIO						
CAVALLETTO STABILIZZATORE	1	1	1	1	1	1
RUOTE INTERNE O ESTERNE	ESTERNO	ESTERNO	INTERNO	ESTERNO	ESTERNO	ESTERNO
NUMERO DI ASSALI	1	1 o 2	2	1 o 2	2	2
RUOTA DI SCORTA (INTERNA O ESTERNA)						
COLORI TRA CUI SCEGLIERE (ALTRI COLORI SU RICHIESTA)						
2 PORTE POSTERIORI AD APERTURA TOTALE						
APERTURA DELLA TENDA CON PISTONI COMPENSATORI						
APERTURA PEDANA CON PISTONI COMPENSATORI						
LUCE INTERNA						

STANDARD OPZIONALE IMPOSSIBILE

	PESO A VUOTO(KG)		PESO TOTALE AUTORIZZATO A CARICO F2 (KG)		LUNGHEZZA (M)		LARGHEZZA (M)		ALTEZZA (M)						APERTURE (M)		VOLUME (M ³)
	1 ASSALE	2 ASSALI	1 ASSALE	2 ASSALI	INTERNO	ESTERNO	INTERNO	ESTERNO	INTERNO (ALL'INGRESSO)			ESTERNO (* ALTEZZA STANDARD)			PORTA LATERALE CON SERRATURA	APERTURA LATERALE A TENDALINO	
									H1	H2	H3	H1	H2	H3			
OLYMPIUM 260	380		DA 750 A 1300		2.55	3.85	1.50	2.10	1.53*			1.95*			1.02 x 0.50	0.85 x 1.55	5
OLYMPIUM 300	450	530			3.00	4.34	1.74	2.35	1.56*	1.69	1.97	2.00*	2.16	2.44	1.02 x 0.50	0.85 x 1.55	7.2
OLYMPIUM RI		660	DA 1300 A 3000		3.00	4.34	1.74	1.91	1.48*			2.00*			1.02 x 0.50	0.85 x 1.55	7.2
OLYMPIUM 360	500	570			3.55	4.94	1.74	2.35	1.56	1.69	1.97*	2.00*	2.16	2.44*	1.26 x 0.56	1.25 x 1.85	10.7
MAXIPODIUM 400		880	DA 2000 A 3500		3.90	5.10	1.78	2.30	1.56	1.69	1.97*	2.00	2.16	2.44*	1.26 x 0.56	1.25 x 1.85	13.37
MAXIPODIUM 500		1080			4.90	6.10	1.78	2.30	1.56	1.69	1.97*	2.00	2.16	2.44*	1.26 x 0.56	1.25 x 1.85	17.11

NOTA: ALTEZZA H1 = MENO DI 2 M FUORI TUTTO = NESSUN SUPPLEMENTO PEDAGGIO AUTOSTRADALE.

FAUTRAS Cruiser



FAUTRAS Carrera



FAUTRAS Tack



Un sito di vendita online di pezzi di ricambio.



Fammi vedere!



boutique.fautras.com

VANS FAUTRAS
24230 MONTCARET
FRANCE

www.fautras.com
contact@fautras.com

FAUTRAS